

DUAL PLACEMENT Place Either Or
Place D105, D106, D107 or Only D100

© TAIT ELECTRONICS
ORCA : 400-470MHZ
POWER AMPLIFIER
IPN: 220-01603-10 ISSUE: A 2.SC. 2
PROJECT: ORCA DESIGNER: BRD FILE NAME: 160310a FILE DATE: 9-Aug-02 NO SHEETS: 7

REV/ISS	AMENDMENTS	DRAWN	CHKD	D.O.	APVD	DATE
A						

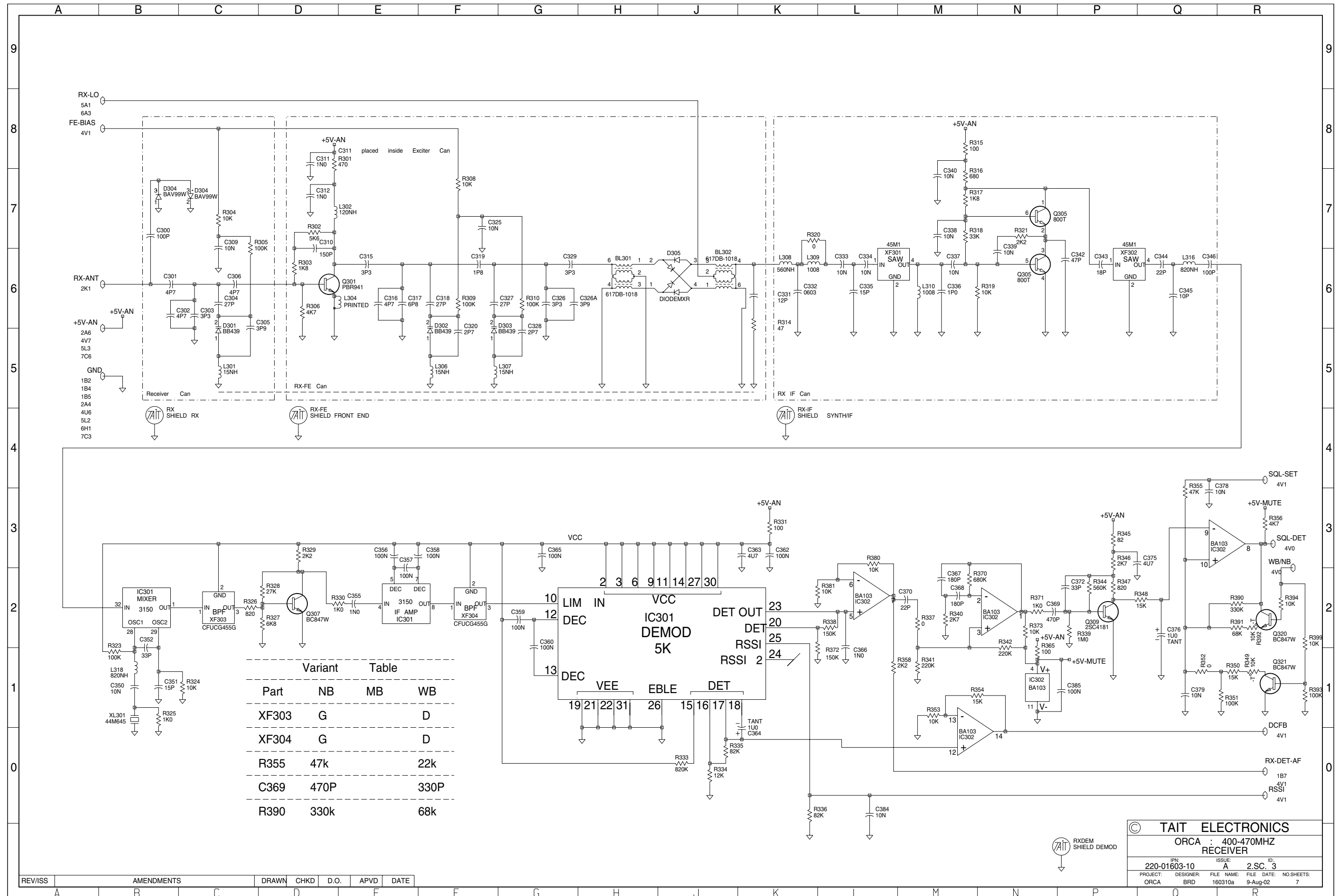

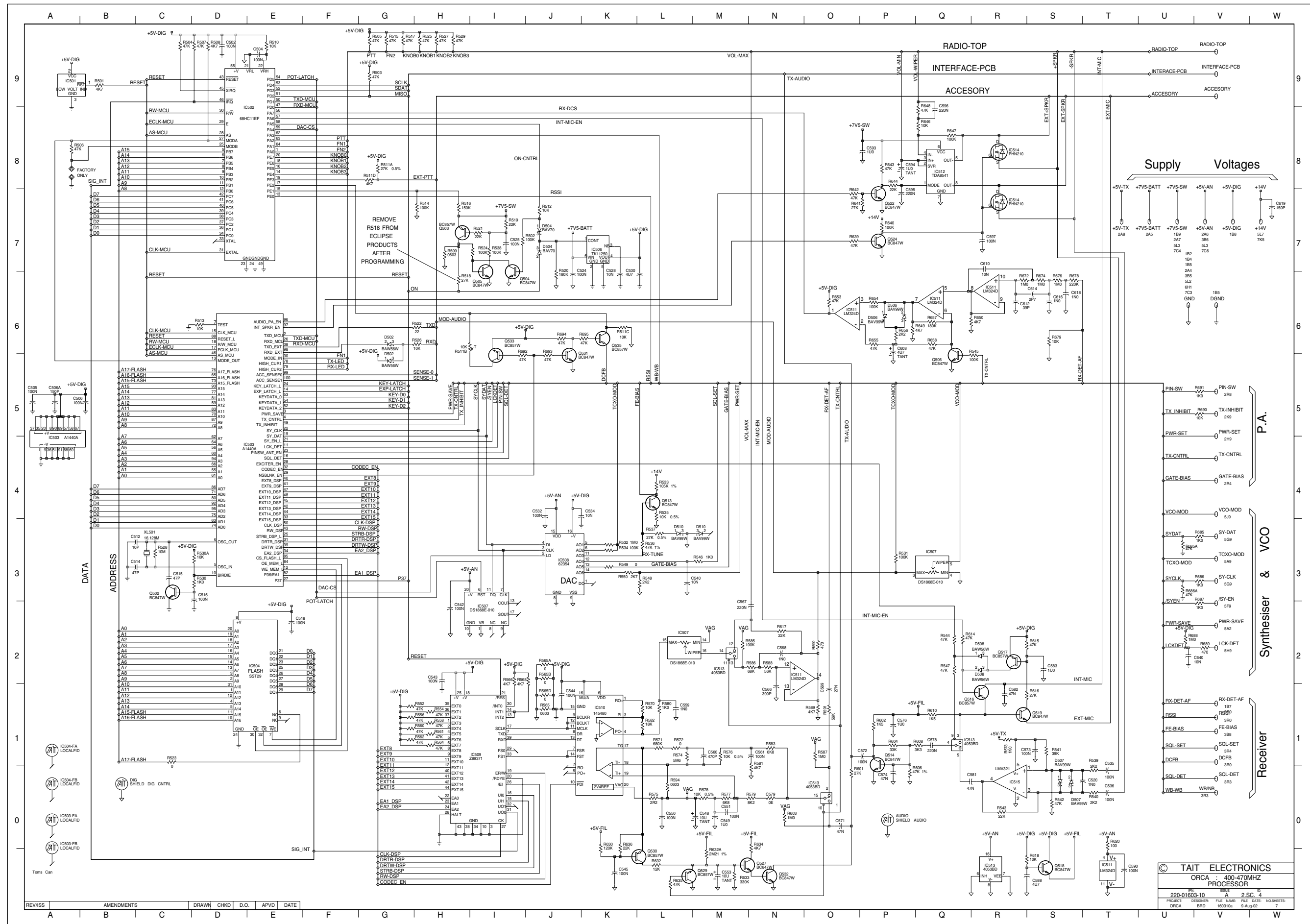

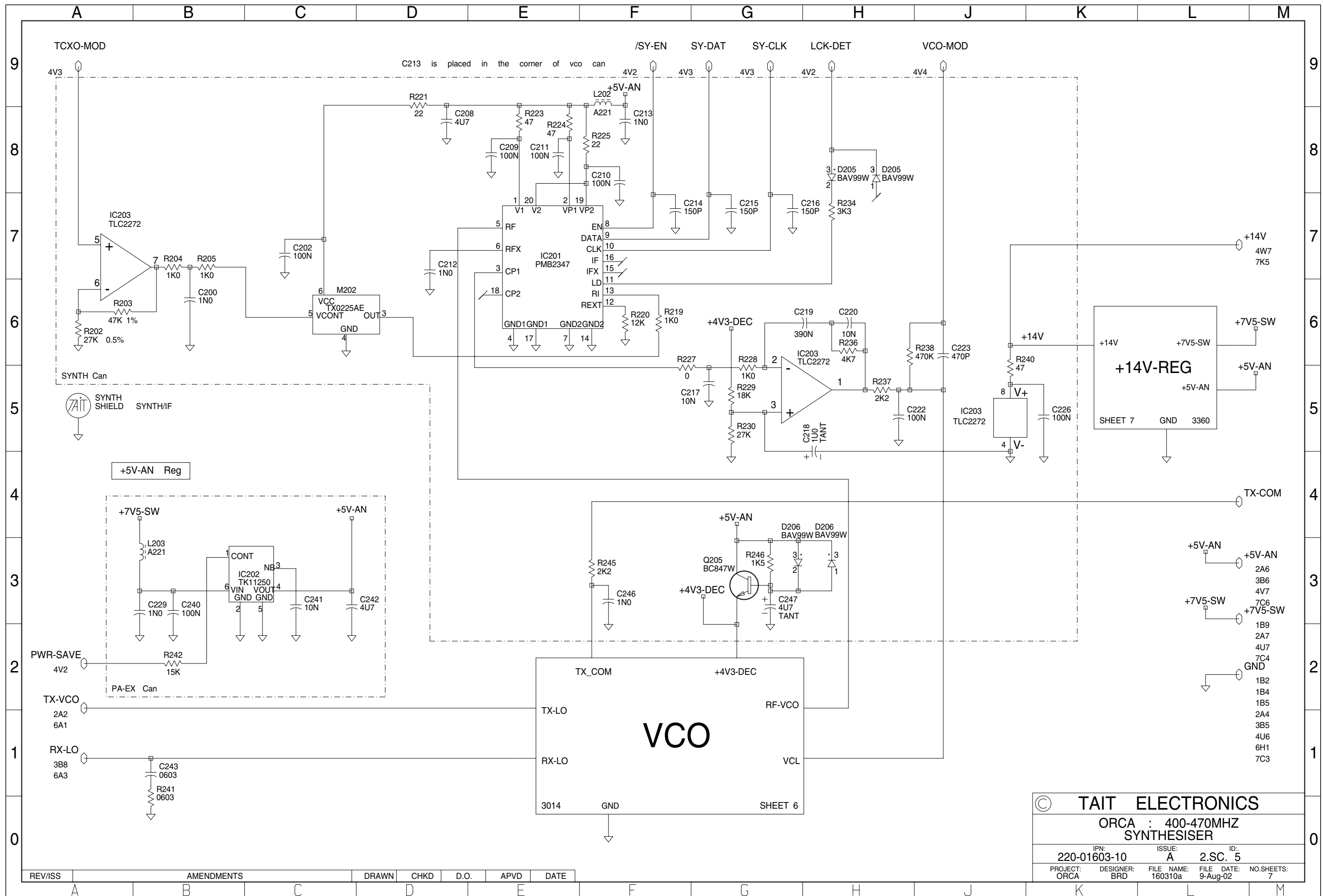

© TAIT ELECTRONICS				
ORCA : 400-470MHZ SYNTHESISER				
IPN:	ISSUE:	A	ID.:	2.SC. 5
220-01603-10				
PROJECT:	DESIGNER:	FILE NAME:	FILE DATE:	NO.SHEETS:
ORCA	BRD	160310a	9-Aug-02	7

REV/ISS	AMENDMENTS	DRAWN	CHKD	D.O.	APVD	DATE
A						

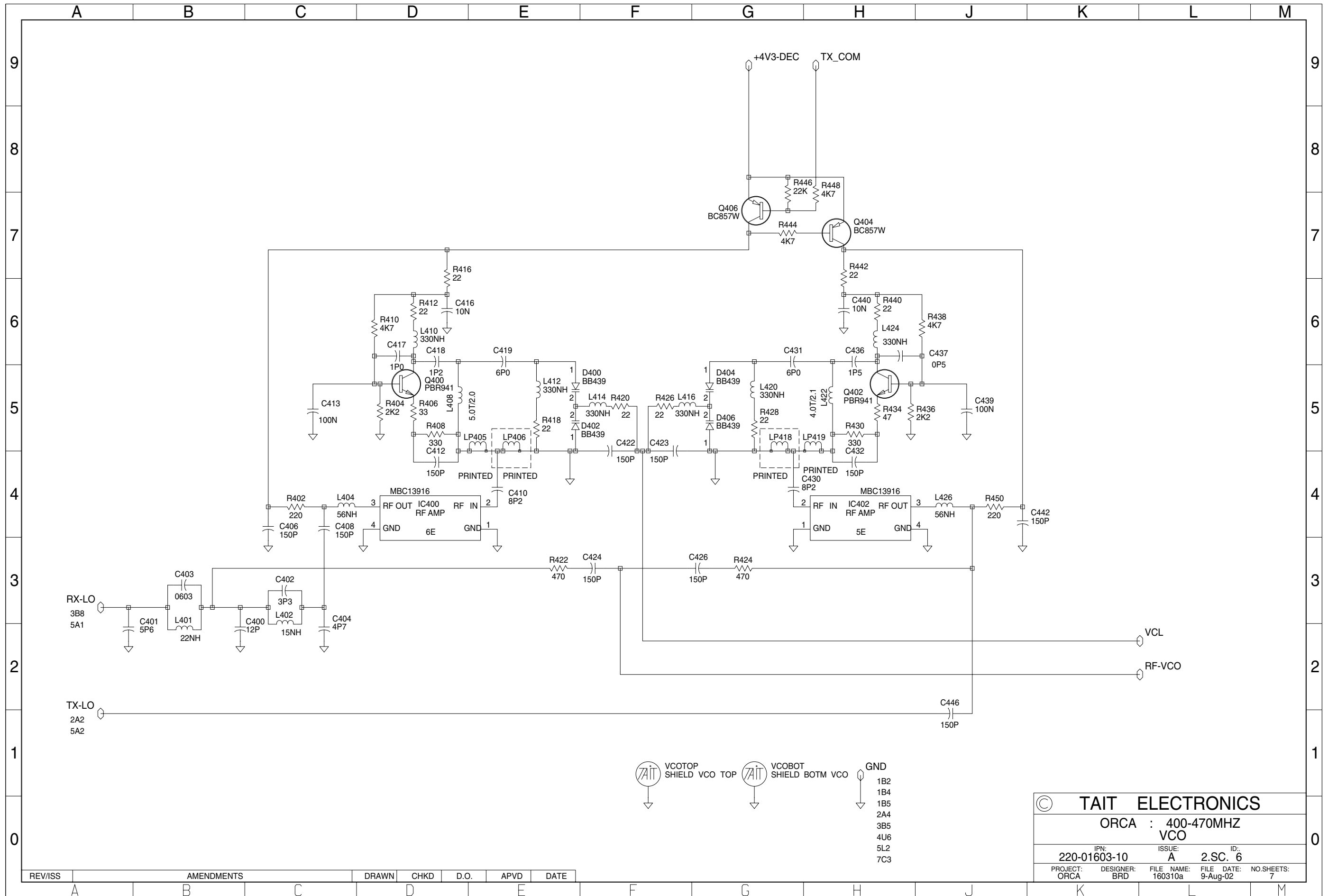

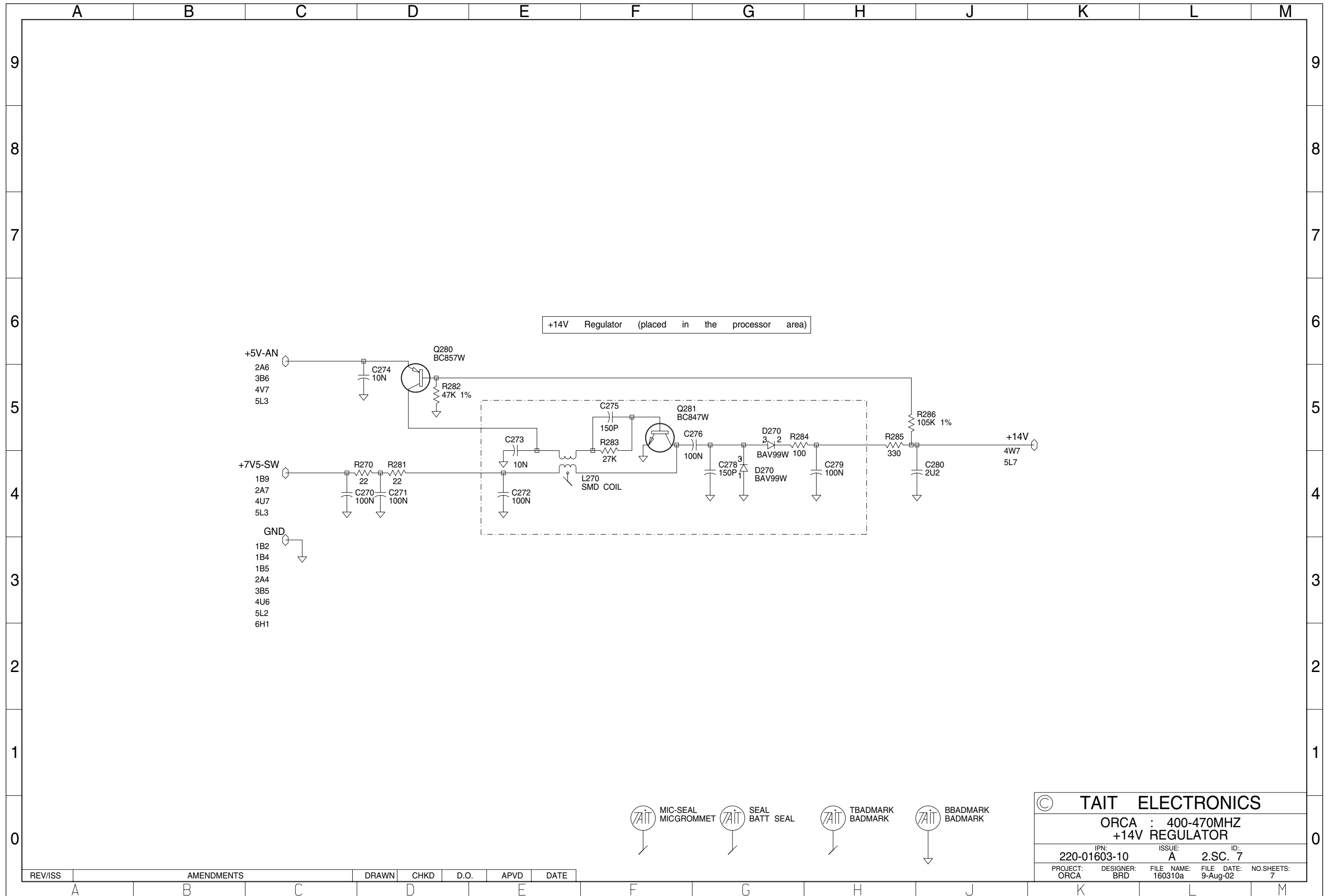

- MIC-SEAL
MICGROMMET
- SEAL
BATT SEAL
- TBADMARK
BADMARK
- BBADMARK
BADMARK

TAIT ELECTRONICS				
ORCA : 400-470MHZ +14V REGULATOR				
IPN: 220-01603-10	ISSUE: A	ID.:	2.SC. 7	
PROJECT: ORCA	DESIGNER: BRD	FILE NAME: 160310a	FILE DATE: 9-Aug-02	NO.SHEETS: 7

REV/ISS	AMENDMENTS	DRAWN	CHKD	D.O.	APVD	DATE
A						